



ULTRA FLUSH® Pressure-Assist Toilet 17" High, Elongated

12" Rough-in



Features:

- Low Consumption 1.6 gpf (6.0 Lpf)
- Elongated Bowl
- Extra Seat Height
- Pressurized Flushing Action
- Close Coupled Flushometer Tank
- Siphon Jet
- Front Tank Lever
- Available With Tank Lever On Right Side – By Special Order
- 2 Bolt Caps
- ADA Compliant

Dimensions:

Height	30 1/2"
Width	20 1/4"
Depth	28 3/4"
Rough-in	12"
Water Surface from Rim	4 1/2"
Trapway (min)	2"
Water Surface	12" x 10"
Water Seal	2 1/2"
Shipping Weight	.94 lbs



Specifications: Bowl — #21-377 Elongated Bowl Tank — #28-380
Seat not included

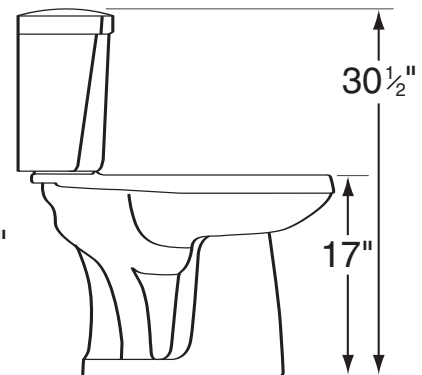
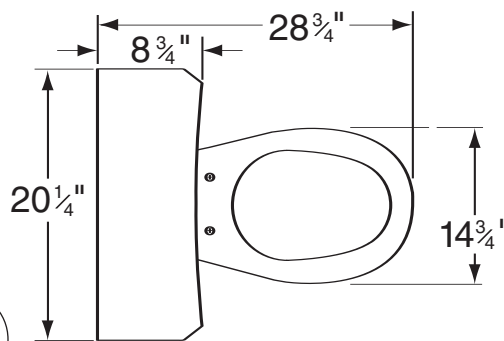

THIS FIXTURE QUALIFIES ACCORDING TO ASME TEST PROCEDURES AS A LOW CONSUMPTION WATER CLOSET WITH AN AVERAGE CONSUMPTION OF 1.6 gpf (6 Lpf) OR LESS.



GERBER®
YOUR BUSINESS. YOUR BRAND.
www.gerberonline.com

Job Name	
Date	
Model Specified	
Quantity	
Customer	
Contractor	
Architect/engineer	

1.6 gpf (6 Lpf) LOW CONSUMPTION ULTRA FLUSH® TOILET 21-318

GERBER®

17" High Elongated, 12" Rough-in
(Bowl 21-377 with Tank 28-380)

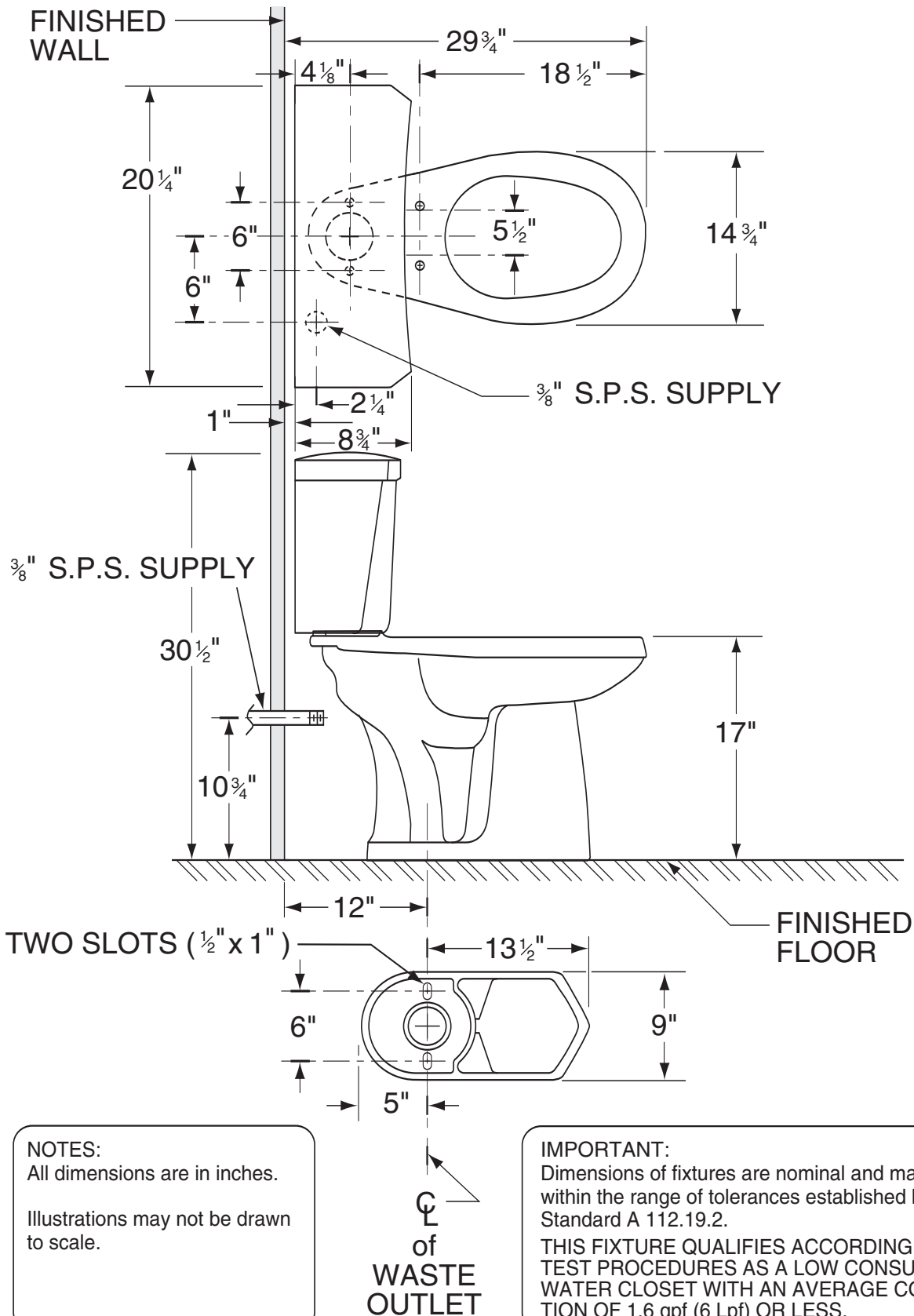

NOTES:
All dimensions are in inches.
Illustrations may not be drawn to scale.

IMPORTANT:
Dimensions of fixtures are nominal and may vary within the range of tolerances established by ASME Standard A 112.19.2.
THIS FIXTURE QUALIFIES ACCORDING TO ASME TEST PROCEDURES AS A LOW CONSUMPTION WATER CLOSET WITH AN AVERAGE CONSUMPTION OF 1.6 gpf (6 Lpf) OR LESS.

CL
of
WASTE
OUTLET